



**Surface Compatibility and the Use of the
Steramist™ BIT™ Systems:**

Written by: Dr. Helene Paxton, MS, MT(ASCP), PhD, CIC, Infection Preventionist, Bio Guidance, LLC.



Surface Compatibility and the Use of the SteraMist™ BIT™ Systems:

Written by: Dr. Helene Paxton, MS, MT(ASCP), PhD, CIC, Infection Preventionist, Bio Guidance, LLC.

The Issues:

Recently, there has been a series of white papers and webinars discussing the effects of disinfectants on surfaces. The white papers outline the damage causing effects of the active ingredients of many disinfectants (quaternary ammonium compounds, bleach containing agents, alcohols, and high concentration peroxide) on fabrics, plastic and metals. Two issues make these studies challenging to evaluate impact in actual care settings. Most Environmental Protection Agency (EPA) claims are made for disinfection efficacy and log kill against microorganisms exclusively on hard surfaces, and do not address the physical damage associated with the disinfectant on surfaces as part of their review.

By focusing on log reduction, the EPA has set standards on organism reduction without requiring comment on environmental damage to materials these organisms are found upon. Solutions of Sodium Hypochlorite, better known as bleach, are used typically at a 1:10 dilution or 5500 ppm. The damage by oxidation is well known and has been well studied; attempts to reduce the use of bleach because of its oxidative properties are on-going. Many other agents have been investigated that are less damaging but do not have the sporicidal properties. Since most bleach formulations do kill *C. diff* spores, its use has continued in healthcare.

Unfortunately, the healthcare environment is not just composed of hard, non-porous surfaces. A patient's environment is filled with a variety of soft fabrics (linen, cotton, polyester, and blends) and plastic polymers found on wheel chairs, mattresses, curtains, window treatments, and other items such as blood pressure cuffs, stethoscopes, etc. Instrumentation including monitors, computers, basins, and other items are made of plastic(s) that can be damaged and pitted by the disinfectant interaction with the material. Most manufacturers will try to deal with the issue by listing "compatible" cleaners for their equipment in their instructions for use. The Joint Commission then charges the hospitals to follow the manufacturers exact instructions. Disturbing is that there is little effectiveness data to support the use of the recommended agents, but purchasers must follow the instructions or void their warranty and fail Joint Commission review. Unfortunately for the hospital systems, this leads to having to handle a variety of disinfection agents and confusion for the staff as to how to use and the corresponding dwell time for each agent. Additionally, there are no stated limits as to how many times an agent can be used without associated damage on the device or instrumentation. Often the only clues are most likely visual and include developing brittleness, fogging of monitor screens, splitting of plastic surfaces, and oxidation of metal surfaces.



The Damage:

Stated damage associated with the traditional disinfectants as mentioned above includes discoloration, hardening and cracking of plastics, associated brittleness, cracking of rubberized materials, and oxidation of metals, etc. As the damage occurs, there is opportunity for bacteria and other agents to become embedded in the seams and tears of the fabrics and pitting or cracking of other surfaces, adding to the risk of contamination and infection for the user. The subtle damage to surfaces is rarely recorded and really does not get addressed until the damage is obvious. How many healthcare institutions do routine visual inspections of their mattresses, stretchers, stainless steel carts and poles, wheel-chairs? How often are the damaged items pulled out of service when a tear or damage is found? How often are we faced with rust covered stainless steel items or damaged aluminum parts? And often, trying to save the cost of replacement, these items will be patched, or repaired creating a riskier environment and opportunity for contamination.

TOMI™ Environmental Solutions, Inc., has recently received EPA registration of its SteraMist™ BIT™ technology for use as a Healthcare-Hospital Disinfectant with a specific claim of 99.9999% kill of *Clostridium difficile* spores. Now registered in all 50 states, The TOMI™ | SteraMist™ BIT™ system uses an activated peroxide solution compromised of ~7.8 % peroxide passed through a cold plasma arc.

System Overview:

- Binary Ionization Technology® (BIT™) was developed by Defense Advanced Research Projects Agency (DARPA) to neutralize weaponized anthrax spores on the chemical suits of first responders, indoor objects/surfaces, and space;
- Innovative application method creates Activated Ionized Hydrogen Peroxide (AIHP) fog/mist starting with a low percentage hydrogen peroxide based solution;
- When exposed to cold plasma activation, low percentage hydrogen peroxide is converted to OH ions (hydroxyl radicals), a type of a ROS (Reactive Oxygen Species). In atmospheric science the hydroxyl radical (OH) is known as the primary cleansing agent of the lower atmosphere;
- The by-products of the AIHP are oxygen and a bit of humidity (water), far safer to handle than those left by conventional methods;
- No wipe, no rinse, leaves no residues;
- SteraMist BIT is EPA registered for use as a Healthcare-Hospital disinfectant for common hospital pathogens, including *C. diff*, MRSA, *Pseudomonas*, and H1N1 viruses among many.



The properties of the system make it a good candidate as an agent which could minimize environmental damage with continued use while demonstrating highly effective disinfection properties. Since no industry standards exist for testing agents against surfaces, we must examine available studies.

The Studies:

Since its development by DARPA, and its previous owner Titan Defense, SteraMist™ BIT™ has undergone extensive materials compatibility testing. TOMI™ Environmental Solutions, Inc. collated and reviewed the studies to answer some of the questions and investigate possible effects of the system on the environment found specifically in hospitals and other facilities. As described, the technology is composed of a low concentration hydrogen peroxide solution passed through a high energy atmospheric cold plasma activation, which produces hydroxyl radicals. The cold plasma arc converts approx. 75%-80% of the hydrogen peroxide to the reactive oxygen species, leaving about 2.5% peroxide unreacted per milliliter of solution. Since we all use 3% hydrogen peroxide in our homes, this should not be viewed as a particularly significant issue for the end user.

(1) The initial study performed by the developer involved dipping various fabrics found in healthcare into the BIT™ Solution as described above. These included Dow Chemical's SARANEX™ which is often used as coating of Personal Protective Equipment (PPE) for first responders, used in medical appliances such as ostomy devices, textile laminates, etc. This material is affected by photo degradation and by abrasion, but is not affected by acids, bases, and other chemicals according to DOW specifications. The material was dipped for 10 days in full concentration BIT™ Solution (without activation through the plasma arc), with little change. The inner layer of the material was a polyolefin resin known as SARAN. The weight of the fabric swatch was changed by .005 grams, a 1.1% decrease. 200D taffeta polyurethane was similarly tested with no noticeable change in color and texture and had a 3.6% increase in swatch weight. Other materials were tested with minimal effect after 10 days in the solution. As a result of the glues fabrics which were bonded to other materials did show some effect after being **immersed** for 10 days. The above study suggested that the peroxide solution was environmentally friendly even at a 7.8% concentration after unusual and improper applications. Since SteraMist™ BIT™ has a ~75% conversion rate of H₂O₂ to OH (hydroxyl radical) ions, the change to fabrics should be minimal especially since the fabrics are not immersed in the solution for disinfection.

(2) A second study looked at metals used in the aerospace industry and other industries such as Pharma. The study tested the metals with 100 hours of exposure to the **activated** BIT™ Solution sprayed onto the surfaces. Metals included copper alloys, stainless steel aluminum, brass, nickel alloys, etc. All the metals showed less than a 1% change, (the C-17 and Army (ECBC) criteria) most having less than 0.1% change in weight. Part of the same study looked at other materials such as Teflon, neoprene, silicone O-rings, glass, and polycarbonate. Similar to metals, all non-metals had less than a 1% change in weight except



for neoprene which had a 1.2% gain in weight. As noted above, the conditions tested were extreme and far more than would be found in a hospital or healthcare environment.

As part of this study, a dip test was performed on 33 different metals and 6 non-metals for 7 days at 100 degrees F. The samples were pulled at 24 hours and examined for corrosion and weight change then placed back in the solution. There was no weight change or visual change except slight discoloration or dulling in 7/33 metal sampled and 2/6 non-metals for each of the samples tested, again suggesting that the BIT™ Solution could only be minimally corrosive and that would be only if it was excessively exposed under extreme conditions.

(3) A third study looked at components that might be found in a clean room environment. Each item including door knobs, switches, light panels, PVC parts, etc. were subjected to the following conditions:

- The tests conducted were intended to simulate the conditions that the materials would be subjected to under normal bio-decontamination cycles. The tests were carried out inside an enclosure with a volume of approximately 0.25 m³. A cycle was developed for the enclosure to achieve a log 6 reduction in bio burden which was validated using a biological indicator challenge (spore strip).
- The test cycle included an injection phase of 3 minutes followed by a dwell phase of 5 minutes and an aeration phase of 5 minutes. The BIT Solution injection rate was 5ml/min giving a total BIT Solution volume of 15 ml for the cycle.
- Sample pieces of the materials were placed inside the enclosure on wire racks or individually hung to ensure total surface contact with AIHP on the material.
- Repeated cycles were carried out until a total of 1000 cycles were completed equating to 160 hours of exposure to the AIHP. The samples were examined for signs of degradation, discoloration or oxidation at intervals of 100 cycles.

The system set up is as per the diagram below:

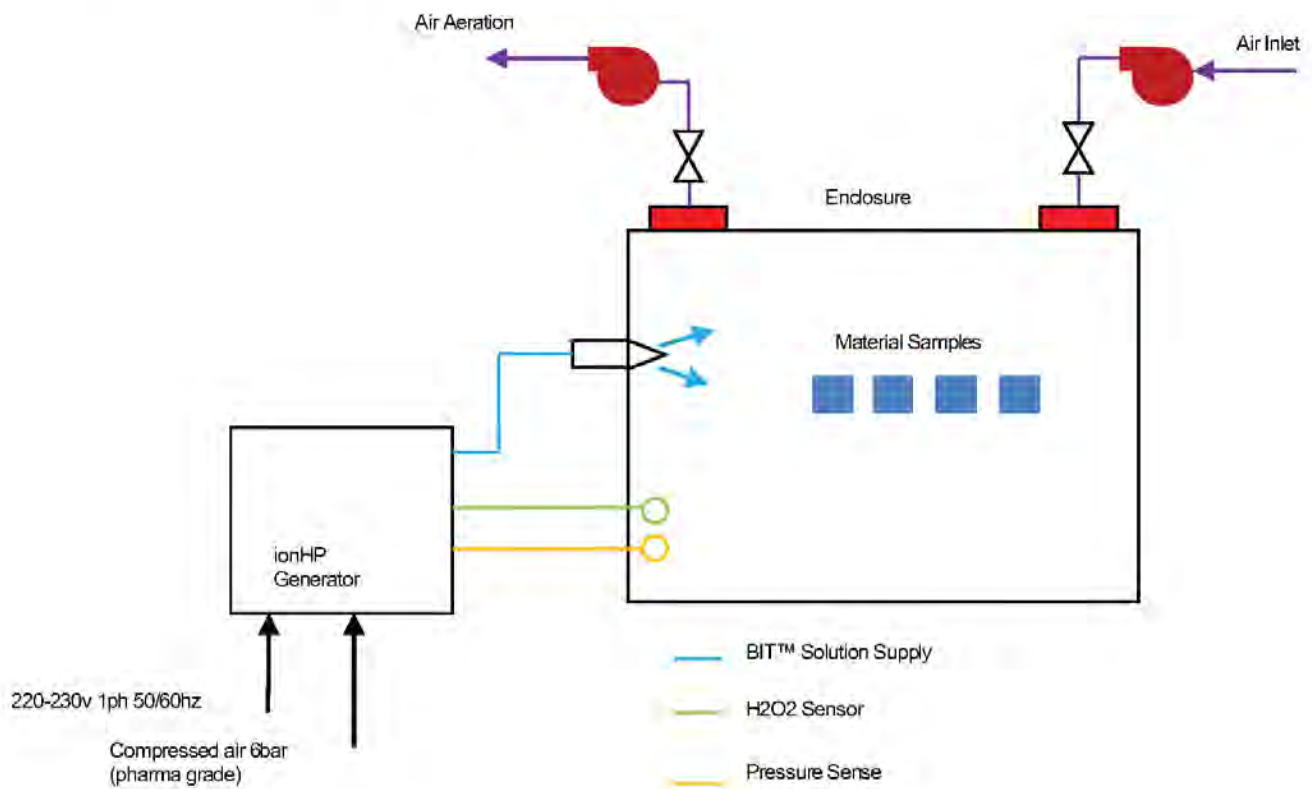

Each item tested, as in studies 1 and 2, was examined for color change, oxidation, and other physical changes. With most items, any change was found to be minimal and was primarily visual, such as a white powder on metal surfaces, or bubbling of certain plastic surfaces. In each case, the items had extreme prolonged exposure far beyond the scope of use which would not be the case in routine Pharma or hospital use.



In Conclusion:

In real-time applications in relationship to the disinfection of a healthcare facility, the SteraMist BIT systems achieve maximum efficacy in a relatively short time. The SteraMist Surface Unit - a fully portable, hand-held, point and spray disinfection/decontamination system has an EPA registered application time of five seconds per square foot and a seven-minute contact time.

The use of any disinfectant whether in a hospital environment, Pharma, or the aerospace industry will have some effect on surfaces whether hard or soft. The selection of the disinfectant depends on the role and the efficacy of the product for a particular use. The disinfectant industry has no reliable testing standards to validate the physical effects of disinfectants on soft fabrics and hard surfaces, no matter their composition; yet, the user has to maintain a safe environment with regards to the potential microbiological contamination of the environment. There is little EPA data on soft fabrics as to the effectiveness of the disinfectants in micro biocidal properties, again leaving the user at a loss. Use of the SteraMist system is a reasonable approach to general disinfection in a variety of environments with little effect on surfaces, whether metal, plastic or fabric.

Ref. Titan Corporation | Protocol: **BIT COMPATABILITY TEST** | date: **19 Aug 03**